

RELEASE

DATE:

COMPANY:

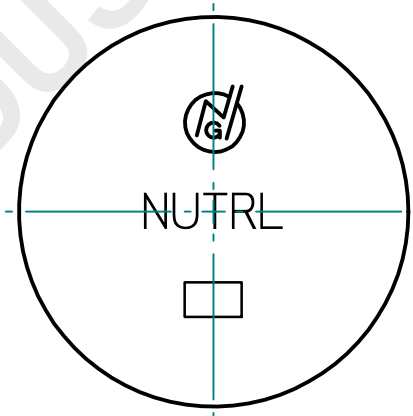
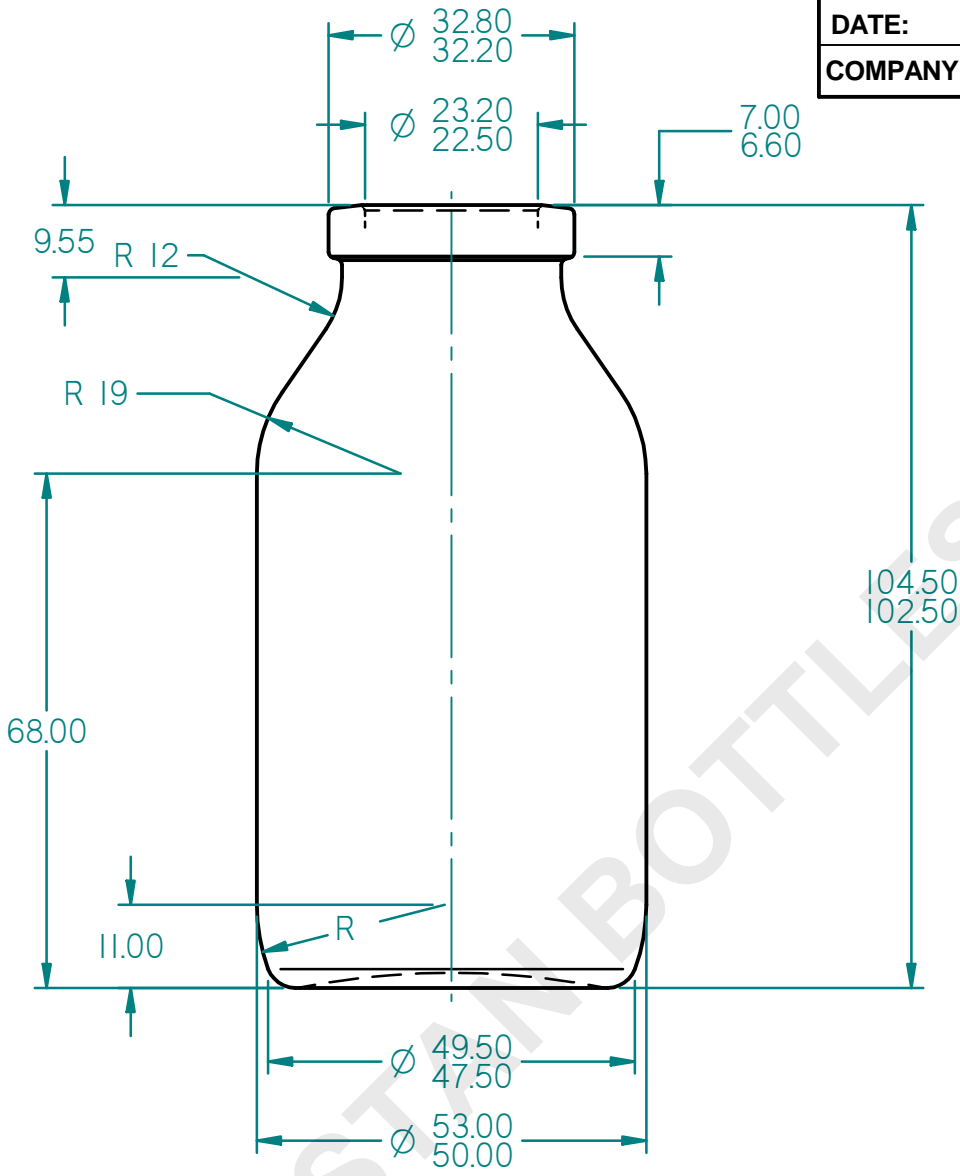

Protective note ISO 16016 observed

GENERAL TOLERANCES DIN 6129-1 (DIMENSIONS WITHOUT TOLERANCES ARE FOR REFERENCE ONLY)				FINISH: 32 mm P.N.		O'FLOW CAPACITY: 130.0 - 140.0 ml		ARTICLE NO.: 5155080100							
				FINISH DWG: NA		WEIGHT: 98 g Approx									
				FINISH MOLD NO: 142		TYPE OF GLASS: I COLOUR: FLINT									
				DATE		NAME		TITLE: 100 ml W / M							
				DRAWN 21/11/2013		Paresh									
				CHECKED 21/11/2013		H.B.P.									
				SCALE 1:1											
				GERRESHEIMER NEUTRAL GLASS & ALLIED INDS. PVT. LTD. MUMBAI / KOSAMBA		MOLD NO.: 145		DRAWING NO.: B 5080		REVISION 0					
										SHEET 1 OF 1		FORMAT A4			
REV.				CHANGE				DATE				NAME			
								FILE: 100 ml WOM.dft							